

REQUIRED TOOLS FOR INSTALLATION

CASSETTE, MODELS S-300 | S-325 | V-80 | V-90

Tape Measure

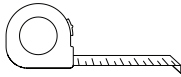

Level

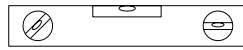

Power Drill / Screwdriver

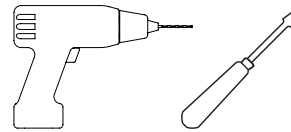

Pencil

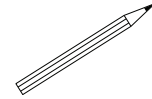

COMES WITH YOUR ORDER

S-300 Brackets

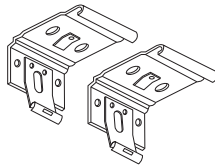

S-325 / V-80 / V-90 Brackets

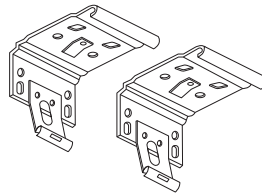

Screws



Applications

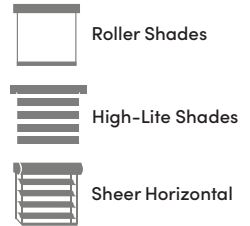

Shade Width (")	# of Brackets Supplied
0 - 60	2
60 - 84	3
84+	4

CASSETTE INSTRUCTIONS

STEP 1 - BRACKET INSTALLATION

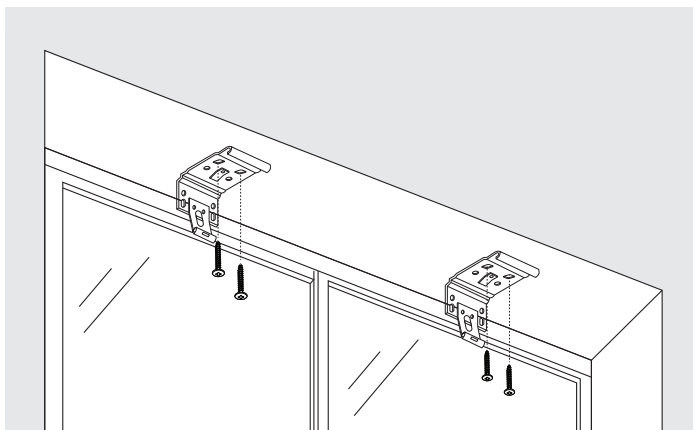

Inside Mount

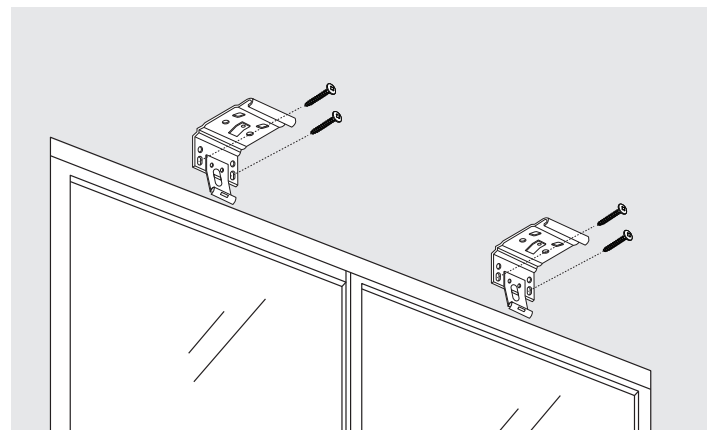

Outside/Wall Mount

Mark the cassette placement on the mounting surface. Install the brackets approximately 2" from either end of the cassette (drywall plugs, if required, can be purchased from a local hardware store). Ensure each bracket is level and in alignment with one another. Brackets should be securely placed allowing slight movement to adjust.

S-300 Cassette

2 7/8" H x 3 1/8" W

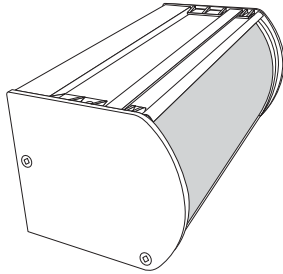

S-325 Cassette

3 1/8" H x 3 1/2" W

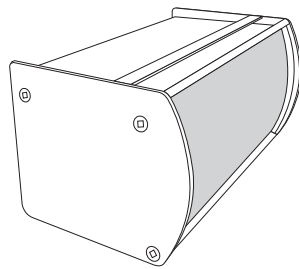

V-80 Cassette

3 3/8" H x 3 1/8" W

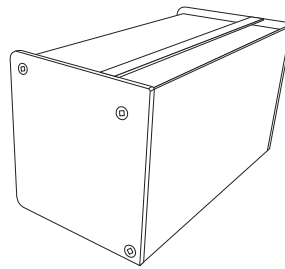

V-90 Cassette

5" H x 3 7/16" W

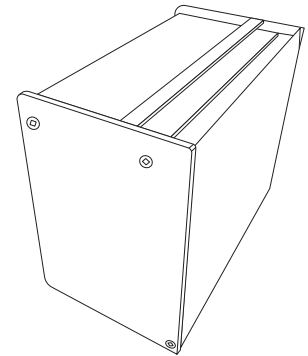

STEP 2 - MOUNTING THE SHADE (S-300 | S-325)

A

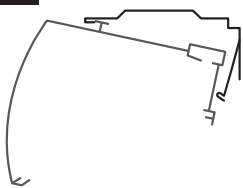

B

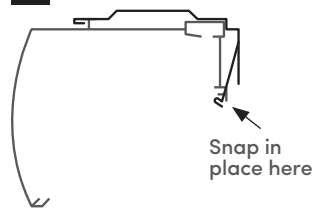

STEP 2 - MOUNTING THE SHADE (V-80 | V-90)

A

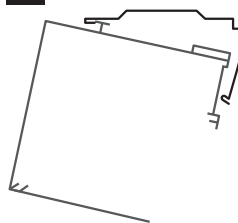

B

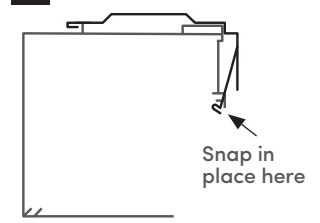

Hook the front of the cassette onto each bracket as shown in (fig.A). Pivot the cassette back and snap into place (fig.B) on each bracket ensuring a tight and secure fit.

NOTES

- DO NOT manipulate fabric roll when snapping cassette into place.

STEP 3 - REMOVING THE SHADE (IF NECESSARY)

S-300
S-325

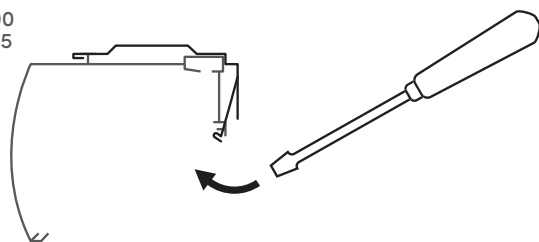

V-80
V-90

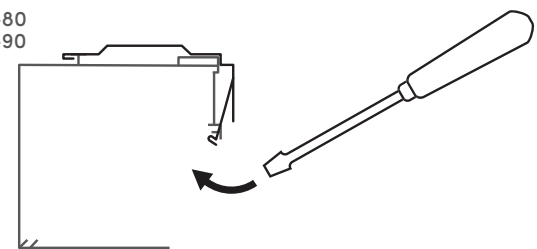

Insert a flat head screwdriver, between the bracket and cassette as shown. Gently pry the spring clip off the bracket of the cassette to unhook. The cassette should disengage from the bracket.

STEP 4 - AFFIX U-CLIP TO WALL (CHAINGUARD™ ONLY)

CHILD/SAFETY CHAIN TENSIONER INSTALLATION

If preferred, the U-Clip can be affixed to the wall to prevent the chain from swaying. Position the U-Clip so it does not interfere with the travel of the shade. Chain should be tight, but not under stress when U-Clip is affixed to the wall. To do so, remove the screw at the front of the U-Clip and gently pry the cover off. Using the wall screw provided, screw the back cover into the wall (**fig.A**). Ensuring the chain is resting properly in the U channel of the U-clip, snap the front cover back on and secure the smaller screw to hold both pieces together (**fig.B**). **Do not twist the chain. ChainGuard™ will rest on U-Clip as shown.**

To operate the shade slide ChainGuard™ up and hold, exposing the chain. Use the exposed chain to raise or lower your shade accordingly.

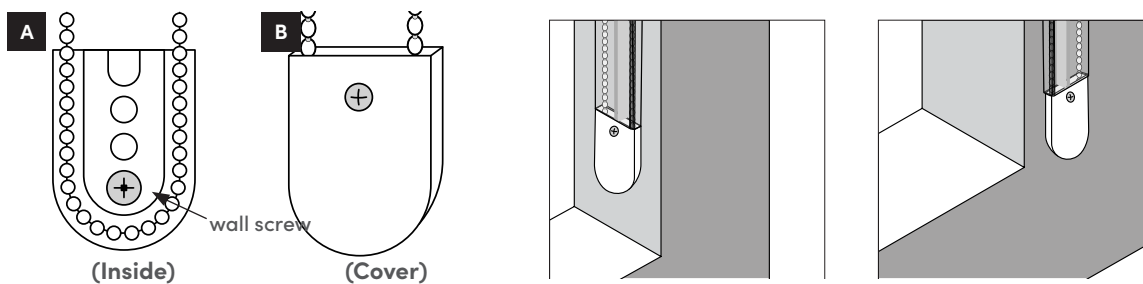

FABRIC ADJUSTMENT

ROLLER SHADES: Roll your shade down a few inches past the window sill and place tape on the fabric as close to the top as possible on the side you want to bring down. Repeat if necessary by layering the tape.

ZEBRA SHADES: Lower the shade and gently tug the front fabric into place so that it aligns with the back.

SHEER HORIZONTAL SHADES: Unlock the plastic clips under the bottom bar and operate the shade up/down until it rolls straight then lock the weight bar back into place.

MAINTENANCE & CARE

Fabrics can be periodically dusted using a soft cloth, can air duster, feather duster, or vacuum cleaner with brush attachment. If staining does occur, most fabrics can be cleaned using a soft cloth with water or a mild soap detergent. Any detergent or cleaning product should be tested on a small area prior to cleaning the fabric. Do NOT use abrasives or harsh cleansers as they can damage the fabric. Dab with a cloth or towel to prevent water spots and roll shade down to the window sill to allow the fabric to air-dry.

⚠ WARNING

STRANGULATION HAZARD: Young children can be strangled by cords. Immediately remove this product if a cord longer than 22cm or a loop exceeding 44cm around becomes accessible.

NOTES

- Tampering with/or removal of ChainGuard™ will affect shade functionality and void the warranty.
- Tampering with cassette will affect shade functionality and void the warranty, unless authorized by the manufacturer
- In order to prevent damage, shades must be installed at least 12" above or 4" in front (open position) of any electric heater(s) or heat sources. Normal forced air does not affect shade if air temperature is less than 32°C.
- Dry environment conditions at various times of the year may generate static on fabric home furnishings, including shades. When this occurs, lightly apply a static spray, ensuring following manufacturer's instructions. Allow the sprayed shade to dry fully. If necessary, repeat the procedure. Optimal humidity should be 35-40%
- All motorized shades are pre-programmed to the length specified on the order.
- Motor antenna wire must not be cut or lengthened. For greatest RF range and optimal performance, the wire must be exposed and should not come into contact with metal/aluminum surfaces. Should your motor not respond, the RF wire may need to be repositioned.

HOW TO OPERATE

CAUTION: Do not lower the shade past the ordered length because damage may occur to the shade.

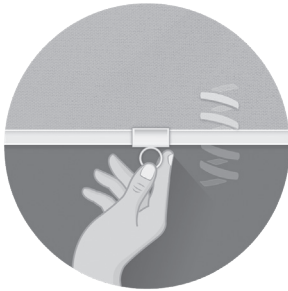

SPRINGDRIVE™

1. To lower your shade, grasp the bottom bar (handle) from the centre-point and gently pull the shade down to desired position.
2. To raise your shade, give a slight pull on bottom bar handle, and the shade will raise automatically in a gradual and controlled motion, stopping at the top.

TIPS

- o Do not pull the fabric beyond the ordered height. Pulling fabric beyond your requested height will expose the tube and could potentially damage your shade.
- o To install the **bottom rail handle**, secure the bottom rail with one hand to prevent the shade from moving. With your other hand, slowly and carefully slide the handle to the centre of the bottom rail.
- o Shade **MUST** be operated from the **centre of the bottom rail** to avoid telescoping and damaging the fabric. If applicable, please ensure the bottom rail handle is positioned in the centre of the shade.

HANDLE

1. Remove the handle from its packaging.
2. Secure the bottom rail with one hand to prevent the shade from moving.
3. Slowly and carefully, slide the handle onto the bottom rail (fig. a).
4. When centered, the handle is fully operational (fig. b).



For french instructions, scan the QR code.

SPRINGDRIVE™ FREQUENTLY ASKED QUESTIONS

1. HOW DO I ADJUST THE TENSION IF MY SHADE ISN'T RISING FAST ENOUGH?

To make your install faster and more efficient, each SpringDrive™ system is pre-tensioned in our factory, and precisely tuned according to the weight and dimensions of your shade. We've taken the guesswork and hassle out of tensioning cordless shades on the jobsite. Shades will rise with a gradual and controlled motion.

If your shade is not performing as desired, it is likely because the brackets are installed too close together, causing too much friction and pressure on the internal spring. A proper installation (for Fascia or Open Roll shades only) will result in a $\frac{1}{4}'' - \frac{3}{8}''$ of space between the idler end and idler bracket. If possible, space the brackets farther apart so that $\frac{1}{4}'' - \frac{3}{8}''$ of space remains between the idler end and bracket.

2. HOW DO I ADJUST THE STOP LIMIT OF MY SHADE?

Each SpringDrive™ system comes pre-adjusted in our factory according to the height of your shade. The bottom bar will extend below the fabric roll by 1"-2". This so the handle or tassel is easily accessible and ensures the fabric does not roll up too far.

Note: Fascia / Open Roll Installation:

When Mounting the shade roll into the brackets, ensure the roll is fully rolled up. This is the stop limit. If the fabric is partially unrolled when the shade is mounted, the shade will only roll up to that point. If fine adjustments are desired, you may remove the plastic adapter disc on the SpringDrive™ end and rotate the shade roll $\frac{1}{4}$ turn up/down as desired. Reinsert the adapter disc ensuring the hooks are facing down. Then mount the shade into the brackets.

3. I HAVE TWO SHADES INSTALLED SIDE-BY-SIDE, WILL THEY OPERATE AT THE SAME SPEED AND STOP AT THE SAME HEIGHT?

So long as you specified side-by-side on your order, your shades will be aligned within $\pm\frac{1}{8}''$ and will operate at a similar speed.

Note:

- a. Side-by-side shades of varying heights will not operate at the same speed.
- b. Twin rollers with blackout and light filtering fabrics will not operate at the same speed.

BASICS Motor User Guide

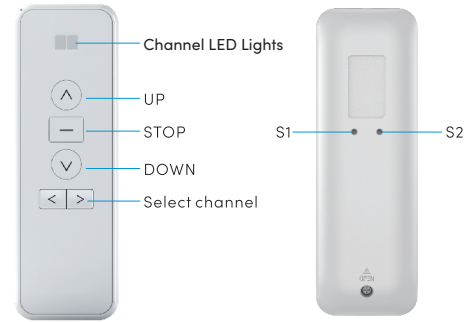
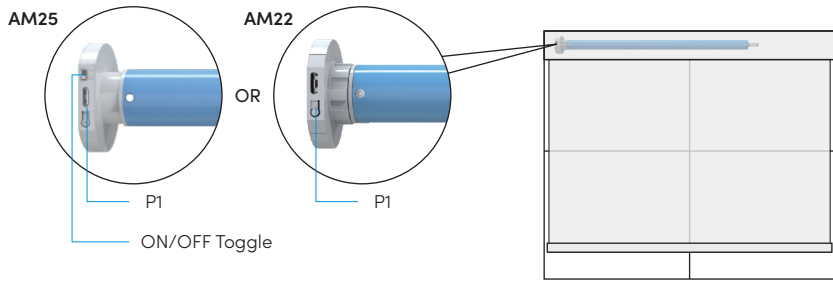

Remote battery: CR2032

I. Operation Instruction

1. Power ON/OFF OR Sleep/Wake

AM25 Model only



Ensure toggle is in ON position. If no toggle, disregard this step.



Press P1 button on motor until motor jogs once and P1 blinks red 3 times. Motor is now asleep.



To wake, press P1 button on motor until P1 flashes red once.



Select channel on your remote, then press P1 button on motor for 1 jog



Press and hold UP until motor jogs once

3. Change Direction (Optional)



Press and hold STOP button for 1 jog



Short press DOWN. Motor jogs once in response



Press S1 on the paired remote until motor jogs once



Adjust to desired lower limit, then press S1 until motor jogs once. Adjust to desired upper limit, then press S1 until motor jogs once



Press S1 until motor jogs once to finish limit setting

5. Speed Adjustment (Optional)



Press and hold S2 until motor jogs (up to 10 seconds)

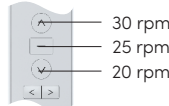

Press "UP" to select highest speed (30 rpm), "STOP" to select medium speed (25 rpm), "DOWN" to select slowest speed (20 rpm)



Press and hold S2 until motor jogs (up to 10 seconds) to save new speed

6. Limit Adjustment



Raise/lower motor to the current set limit, then press S1 until the motor jogs once

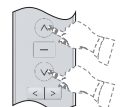

Fine-tune the motor to the desired position



Press S1 until motor jogs once to save settings

7. Jog vs. Continuous Mode

* The default movement of the motor is continuous. Jog mode can be used to tilt High-Lite or Sheer Horizontal Shades in small increments.



Press and hold "STOP" until motor jogs once



Press "STOP" again until motor jogs once

8. Set Intermediate Positions

* Up to 4 intermediate positions can be set



Bring shade to desired intermediate position



Press S1 until shade jogs. Press S1 until shade jogs again

9. Adding Remotes or Channels



On current remote/channel, press and hold "STOP" until motors jogs once



Select new remote/channel and press "UP". Motor will jog in response

10. Deleting Remotes or Channels



Select remote/channel to be deleted and press and hold "STOP" until motor jogs once



Press and hold S1 for 1 second and the motor will jog to indicate successful deletion

11. Factory Reset Using P1

* Make sure the interval between every actions is less than 1s



Press P1 until light flashes red and release



Press P1 until light flashes red and release



Press and hold P1 until light flashes red twice



Press and hold P1 until motor jogs twice. Motor is reset

12. Factory Reset Using Remote

* Make sure the interval between every actions is less than 1s



Select remote and channel for motor and press and hold "STOP" until motor jogs once



Within 10 seconds press and hold S1 until motor jogs 3 times (about 10 seconds)

13. Supplemental Instruction

Intermediate position

- The first and second position are Upper/Lower limit positions. Other four are intermediate positions.
- After the Upper/Lower limit position are set, all the intermediate positions must be set between the Upper and Lower limit.
- The Upper and Lower limit position can only be fine-tuned once set. It can only be removed by resetting the motor.
- Press the UP or DOWN button once and the motor will move to the next pre-set limit position. When the upper position has been reached, the Up button will be unresponsive. When the lower position has been reached, the Down button will become unresponsive.
- Press and hold the UP or DOWN button until the indicator on the programmed channel flashes twice, release, then the motor will move to the Upper or Lower limit position without stopping at any intermediate position.

Power/Charging

- If battery is low, red light will flash, motor will switch to jog mode. Motor will stop working when battery is depleted.
- The light turns to red during recharging. It turns to green when it is fully charged.

II. Troubleshooting

Issue	Possible Reason	Solution
Motor does not move	<ol style="list-style-type: none"> Power is cut off Power shortage protection Incorrect installation leads to motor getting stuck 	<ol style="list-style-type: none"> Switch motor on manually Start the motor after charging it for 6 hours Check all parts are installed properly
Motor stops suddenly during operation	<ol style="list-style-type: none"> Power shortage protection Protect motor when encountering obstacle 	<ol style="list-style-type: none"> The motor will resume working after being charged Check for any obstructions in the path of the shade

III. Motor Information

AM22 Motor				AM25 Motor			
Input: 5V DC	43.2 MHz	1.1A	6.7W	Input: 5V DC	43.2 MHz	900mA	6.7W
Output: 0.5 N.m	25rpm	IP Class: IP 44		Output: 1 N.m	25rpm	IP Class: IP 44	
Battery Capacity: 7.2V/2600mAH				Battery Capacity: 7.2V/2600mAH			

CAUTION: Please charge motor with charger provided at least 6h every 6 months to extend battery life

SETUP CODE CODE DE CONFIGURATION

SBCAN

Getting to know your Smart Controller

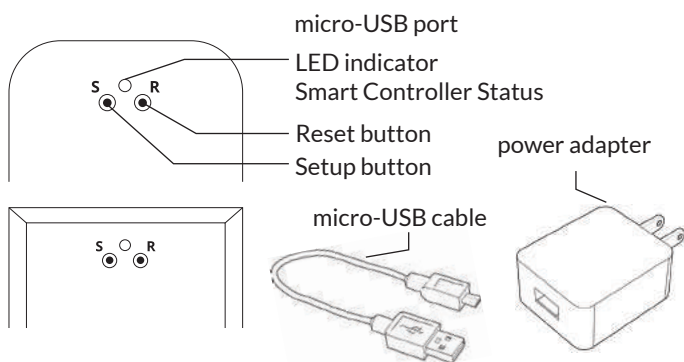

Smart Controller Status:
Flashing blue - Hotspot available
Flashing green - Connecting to the WiFi network
Pulsing cyan/blue-green - Connected to the Internet

Getting Started

- 1 Download the Neo Smart Blinds app**

Download the app to your phone or tablet by searching **Neo Smart Blinds** on Google Play or the App Store.
Note: Do not install Neo Smart Blinds Blue
- 2 Plug in your Smart Controller in reach of your home WiFi**

Choose a place not too far from your home router or a place you know has good WiFi signal strength. You will be able to change its location after, if necessary.
- 3 Create an account and choose the setup code written on the cover**

After opening the app, tap on Create one to create a new account. Enter a valid email address and choose a password, select the region time zone from the place where the Smart Controller will be located. Choose the setup code written in the cover and tap on Register.
- 4 Follow the app step by step to add the Smart Controller**

Have in hand the home WiFi password. It will be necessary to connect the Smart Controller to the Internet.
Note: Some Android users won't be connected quickly to the hotspot. If it is the case, please wait about 10 seconds before returning to the app. During this time, your device may notify you that the hotspot does not have Internet access, and will prompt you whether you want to remain connected. You need to select the option that will allow you to keep connected before returning to the app.

System requirements

- A strong WiFi signal (3 bars or more) in the location where you will setup your Smart Controller.
- The Smart Controller only supports 2.4GHz WiFi (IEEE 802.11b/g/n), not 5GHz. WiFi security needs to be set to WPA-PSK or WPA2-PSK.
- A smartphone or tablet running Android 5.0 (Lollipop) or higher, or iOS 8 or higher is needed.

Troubleshooting

The home WiFi doesn't appear in the step 4

Try rescanning, if the problem persists, you will need to reposition the Smart Controller to a place with stronger WiFi signal. In this case, exit the process (tap on the menu, then tap Your Rooms), replace the Smart Controller and start over.

The Smart Controller LED in the bottom is not blinking blue

The process fails in the last step

Press the S button for 10 seconds, then press the R button once and start over. Pay special attention when typing the WiFi password.

Need more help?

Visit neosmartblinds.com/smartcontroller for detailed instructions about how to use the app and troubleshooting.

Integrations

Smart home devices

Visit neosmartblinds.com/smartcontroller-integrations for detailed information about connecting to Amazon Alexa, Google Home and other systems.

Control4

Please send an email to tech@neosmartblinds.com with your name, your email and your company's name. This information is necessary to always send to you any further driver update.

Legal Information

FCC

This equipment has been tested and found to comply with the limits for a Class B digital device, pursuant to Part 15 of the FCC Rules. These limits are designed to provide reasonable protection against harmful interference in a residential installation. This equipment generates uses and can radiate radio frequency energy and, if not installed and used in accordance with the instructions, may cause harmful interference to radio communications. However, there is no guarantee that interference will not occur in a particular installation. If this equipment does cause harmful interference to radio or television reception, which can be determined by turning the equipment off and on, the user is encouraged to try to correct the interference by one of the following measures:

- Reorient or relocate the receiving antenna.
- Increase the separation between the equipment and receiver.
- Connect the equipment into an outlet on a circuit different from that to which the receiver is connected.
- Consult the dealer or an experienced radio/TV technician for help

Contains transmitter module FCC ID: COFWNMNB11

To comply with FCC/IC RF exposure limits for general population/uncontrolled exposure, the antenna(s) used for this transmitter must be installed to provide a separation distance of at least 20 cm from all persons and must not be co-located or operating in conjunction with any other antenna or transmitter.

IC

This device complies with Industry Canada's licence-exempt RSSs. Operation is subject to the following two conditions:

- This device may not cause interference; and
- This device must accept any interference, including interference that may cause undesired operation of the device.

This device meets the exemption from the routine evaluation limits in section 2.5 of RSS102 and users can obtain Canadian information on RF exposure and compliance.

Contains transmitter module IC: 10293A-WMNB11

This End equipment should be installed and operated with a minimum distance of 20 centimeters between the radiator and your body.

