

ROMAN SHADES

LIFT SYSTEMS: CORDLESS LIFT



The difficulty level of this installation is ranked at **Level 1**. *A piece of cake!*

If you have questions or get stuck, call our Customer Care Team at 888-685-1735, or email info@selectblindsCanada.ca

HARDWARE AND PARTS INCLUDED

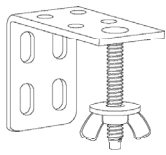

BRACKET WITH WINGNUT



SCREWS

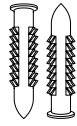

WALL ANCHORS*

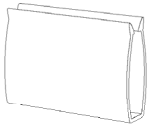

CORDLESS HANDLE

*Recommended if mounting into hollow drywall.

TOOLS REQUIRED



PENCIL

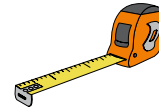

TAPE MEASURE



POWER DRILL



5/64" DRILL BIT



PHILLIPS SCREWDRIVER



STEP LADDER



PHILLIPS DRILL BIT



LEVEL

1. MOUNTING THE BRACKETS

NOTE: Cordless shades have pre-drilled holes in the top of the headrail. You will use these holes as a guide for your bracket placement. If using your own screws instead of those provided, be sure to pre-drill a small hole with a 5/64" drill bit before the final screws go in to attach brackets.

INSIDE MOUNT

1. Grasp the shade by the headrail and hold it up inside the top of the window. Set it back until the front of the shade is flush with the wall. Hold the shade in place, and with a pencil, make a mark through each hole in the headrail. Set the shade aside.
2. Take a bracket and center the drop-bolt over each mark. Use the holes in the top of the bracket to mark where your two screws will go.
3. Align the brackets with the holes, and use a Phillips drill bit to securely fasten the screws.

PRE-DRILLED HOLES

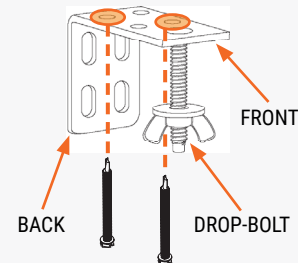
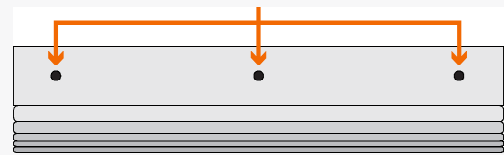

OUTSIDE MOUNT

NOTE: If using your own screws instead of those provided, be sure to pre-drill a small hole with a 5/64" drill bit before the final screws go in to attach brackets.

1. Center and hold the headrail at least two inches above the window. While keeping the shade level, make a small line with your pencil just above each of the pre-drilled holes in the headrail. Set the shade aside.
2. Align the top edge of a bracket along each mark, and use the holes in the back of the bracket to mark where your two screws will go.
3. Align the brackets with the holes, and use a Phillips drill bit to fasten the screws in place.

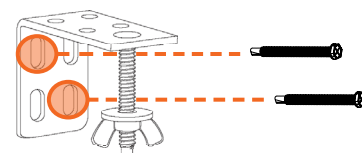
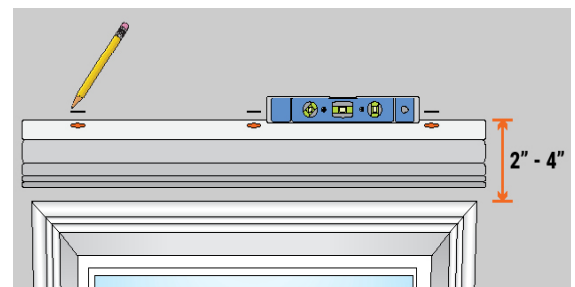

*If you are using wall anchors, pre-drill with a 1/4" bit instead, and tap the wall anchors into the holes with a hammer before drilling in the screws.

2. ATTACHING THE SHADE

INSIDE AND OUTSIDE MOUNT

IMPORTANT: The cords running along the underside of the headrail must be able to move freely. **To avoid tangling or damage to the cords, make sure the “wings” of the wingnut are facing the sides of the window.**

1. Remove the wingnuts from the brackets if you haven't done so already.

2. With the front of the shade facing you, fit the pre-drilled holes of the headrail to each of the drop-bolts on the brackets. While holding the headrail to the brackets with one hand, use your other hand to attach each of the wingnuts to the drop-bolts. Tighten the wingnuts until the shade is firmly held in place .

3. **IMPORTANT:** Please ensure that you fully close the headrail by attaching the headrail fabric together with the hook-and-loop fastening strip.

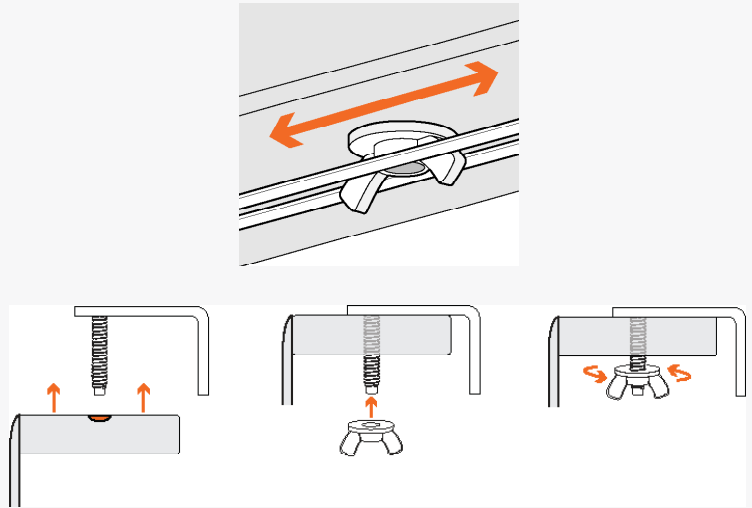

3. ATTACHING THE LIFT HANDLE

CORDLESS ROMAN SHADES

NOTE: Cordless roman shades come with a clear plastic handle to help protect the fabric over multiple uses.

1. At the bottom pleat of the roman shade, locate the sewn-in hem bar.
2. Clip the handle to the center of the bottom hem bar.
3. To operate, grab the handle with your hand, and gently lift or lower the hem bar; the shade will stay in place when released.

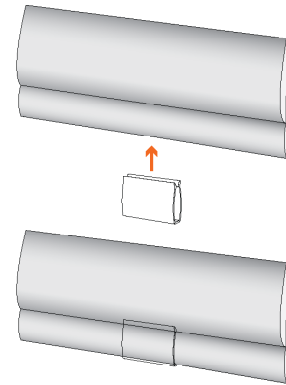

CLEANING INSTRUCTIONS

NOTE: All fabrics are different and some may be easier to clean than others. We recommend cleaning your shades as often as once a month. Here are some general guidelines on how to do so:

1. For regular maintenance, use a duster or a vacuum with a brush attachment and run it over the front and back of the shade.
2. To spot clean stains, use a damp rag with a very mild, gentle detergent or soap. Dab at the affected spots; do NOT rub! Let the dampened area air-dry and repeat as necessary.
3. If your roman shade has wrinkles, you can use a basic steamer to remove them. Hold the steamer roughly six inches away from the fabric and wave the steamer back and forth over the wrinkled areas.

WARRANTY AND REPLACEMENT

To learn more about our product warranties, please visit: <https://www.selectblindscanada.ca/warranty>

For replacement parts, and/or to file a warranty claim for a product that is damaged, defective, or missing parts, please call our Customer Care Team at 888-685-1735, or email info@selectblindscanada.ca.

WARNING

STRANGULATION HAZARD — Young children can be strangled by cords. Immediately remove this product if a cord longer than 22 cm or a loop exceeding 44 cm around becomes accessible.

WOVEN WOOD SHADES

LIFT SYSTEMS: CONTINUOUS CORD LOOP | MOTORIZATION



The difficulty level of this installation is ranked at *Level 1 - A piece of cake!*

If you have questions or get stuck, call our Customer Care Team at 888-685-1735, or email info@selectblindscanada.ca

HARDWARE AND PARTS INCLUDED

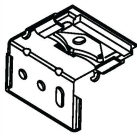

BRACKETS

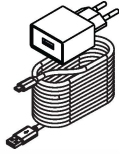

BATTERY CHARGER & CABLE (MOTORIZED)



REMOTE & HOLDER (MOTORIZED)



SCREWS



PLASTIC ANCHORS

*The quantity of brackets you receive will depend on the width of your shade

TOOLS REQUIRED



PENCIL



TAPE MEASURE



POWER DRILL



STEP LADDER



LEVEL



5/64" DRILL BIT



PHILLIPS BIT

1. MOUNTING THE BRACKETS

INSIDE MOUNT

1. Measure **2" - 4"** in from each side of the window frame, and mark once with a pencil for your outer brackets. The front of the bracket will face out from the window, and the back of it will hang down parallel to the window.
2. Next, you'll need to measure how deep to place your brackets in the window. Starting at one of your marks, measure back at least **1"**, and make a mark with your pencil. If you want the front of the cassette to be flush with the wall, measure back **1 1/2"** and make a mark. Repeat this step until you've marked the same depth measurement for each bracket.
3. Hold each bracket up to the ceiling or window frame so back edge of the top of the bracket lines up with your mark. Mark through the top hole in the bracket with your pencil. This is where your screws will go. Repeat this step until you've marked the screw holes for each bracket.
4. Pre-drill the screw holes with a **5/64"** drill bit at your marks for each bracket location. Before you mount the brackets, you may want to erase any pencil marks that remain on the wall or window.

*If you are using wall anchors, pre-drill with a **1/4"** bit instead, and tap the wall anchors into the holes with a hammer before drilling in the screws.

5. Line up your first bracket with the screw holes, and insert a screw to secure the bracket to the mounting surface. Repeat this step for any remaining brackets. When all brackets are secure, you're ready to mount the shade into the window.

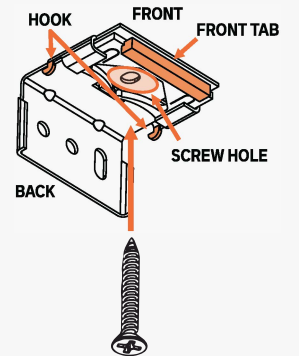
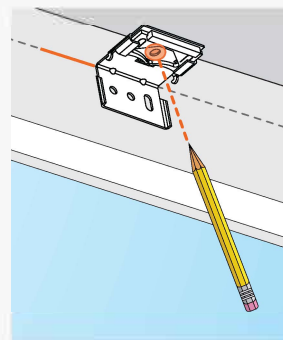
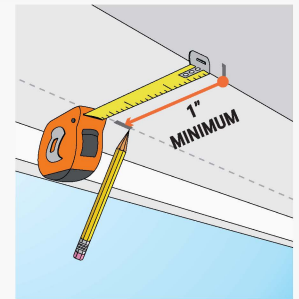
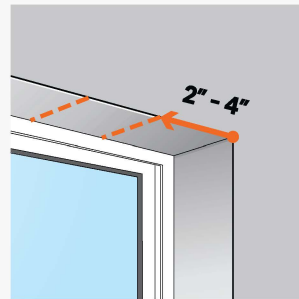

OUTSIDE MOUNT

1. At the top corners of the window, measure inward and mark with your pencil **2" - 4"** from each side. If you have additional brackets, make an additional mark for each one, evenly spaced between the outer marks.
2. From one of these marks, measure upward and mark the height for the bracket placement. The minimum height requirement is **5/8"**, but if you want the bracket to clear at the top of the window, measure and mark at least **1"** above your window. Repeat this until you've marked the same height measurement for each bracket

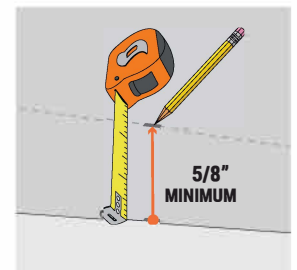
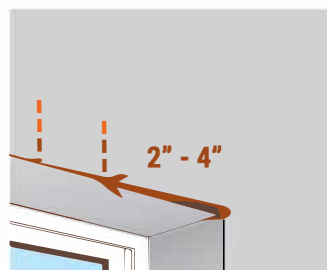

- Position a bracket so that the back is against your mounting surface, and the top is aligned with one of your uppermarks. Hold the bracket in place and mark with your pencil where the screws will go. Repeat this until you've marked the screw holes for each bracket.
- Pre-drill the screw holes with a 5/64" drill bit at your marks for each bracket location. Before you mount the brackets, you may want to erase any pencil marks that remain on the wall or window.

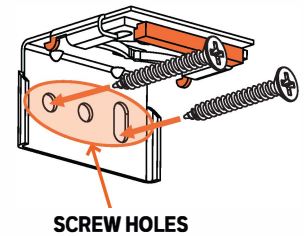
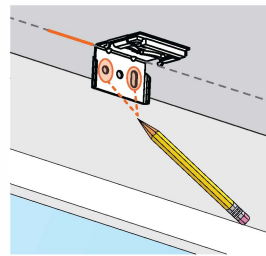

2. ATTACHING THE SHADE

INSIDE AND OUTSIDE MOUNT

- Place the headrail onto the brackets so that the front tab of the brackets fit under the inner front lip of the headrail. Slide the headrail left and right until the shade is centered in or over the window.
- Hold the shade in position, and push the shade backward and raise until the back hook of the bracket snaps onto the back lip of the headrail. The shade is now installed!

STEP 1

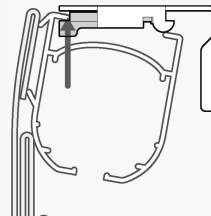

STEP 2

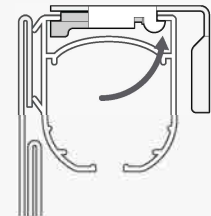

3. ADDITIONAL INSTRUCTIONS

CHAIN SAFETY SHIELD

NOTE: Chain Safety Shields are used to ensure the smooth operation of your shade and to help protect children from getting tangled in loose cords and compliant with the child safety standards. The Shield encases the chain, leaving 8" exposed to easily control the shade.

HOW TO OPERATE

NOTE: Do not pull on the side of the shade fabric; this can cause the fabric to be misaligned or become dirty. A continuous cord loop roller shade should only be operated by pulling the chain.

Pulling gently on the cord in one direction raises the shade; pulling it in the other direction lowers it. On shades where the fabric rolls against the window, the front cord lifts the shade. On shades where the fabric rolls toward the room, the rear cord lifts the shade.

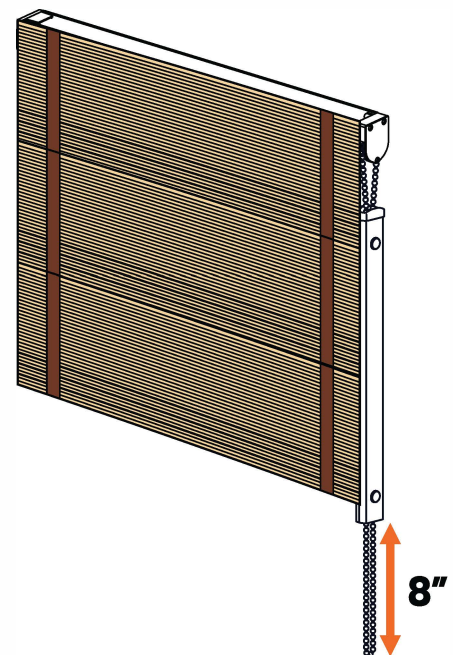

4. PROGRAMMING AND USING YOUR REMOTE

IMPORTANT: The motorized shades were programmed and in sleep mode, please wake up the motors before using. To do this, press and hold the setting button for 6 seconds until you hear the motors sound and the leds flash red four times.

REMOTE CONTROLLER TECHNICAL DATA

• Channels	5+all (RW5-G2) 14+all (RW14-G2)	• Operateion Temp	-20 ... 55°C
• Max. blinds	16 per channel	• Frequency	ASK 433.92 MHZ
• Supply voltage	3V, Cr2350 Coin Cell	• Indoor range*	35m
• Protect Rate	lp20	• Dimensions(W x H x D)	46 x 122 x 12.4 mm
		• Weight**	56 grams

NOTE:

* The indoor range is typically 35m but can vary based on the thickness and material of the walls.

** Including battery.

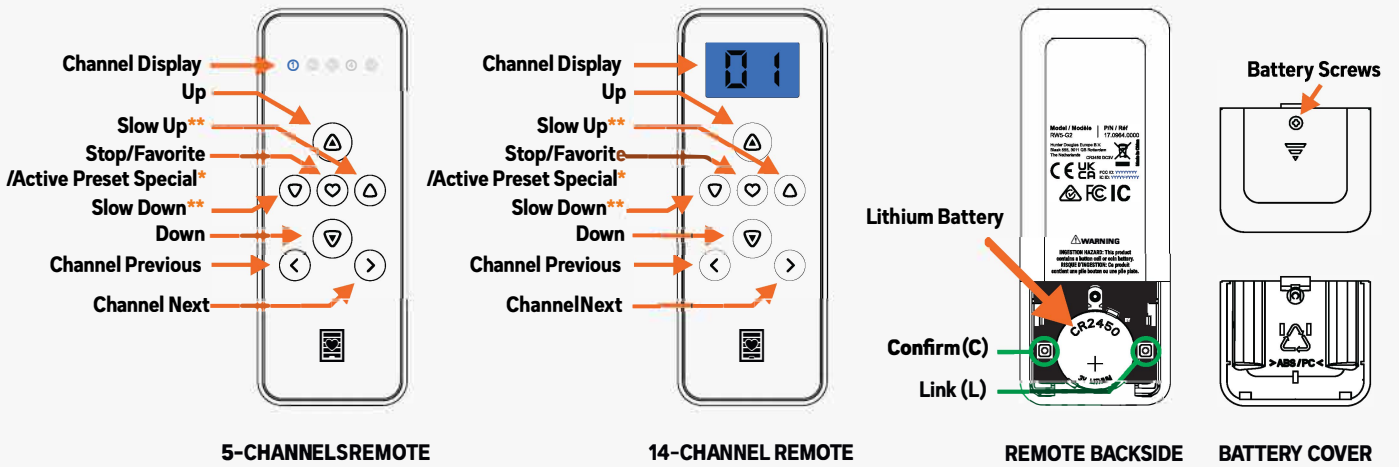

NOTE:

- * Only for certain products
- ** To activate the preset special function, hold 2 seconds and then release.

PAIRING A SINGLE SHADE TO A CHANNEL

1. Select the desired shade **channel** (channel backlight will turn off after 4 secs).
2. Remove the battery cover to access the 'C' button.
3. Hold the **setting button** until the shade **jogs** and the motor's **green** LED blinks.
4. Hold the **setting button** again until the shade **beeps** and the motor's **red** LED blinks steadily.
5. While the motor beeps (max. 15 secs), press the 'C' button. The shade will **jog**, and the **green** LED will flash to confirm successful pairing.

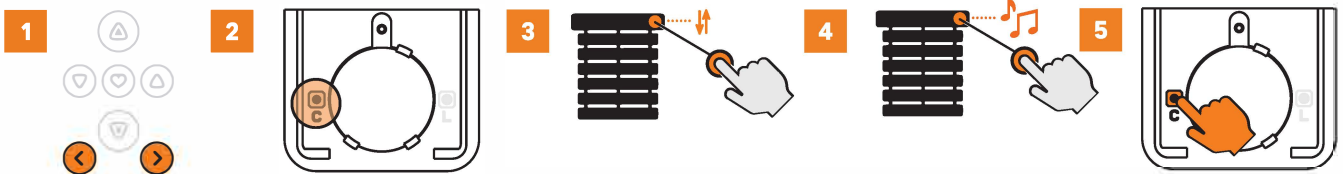
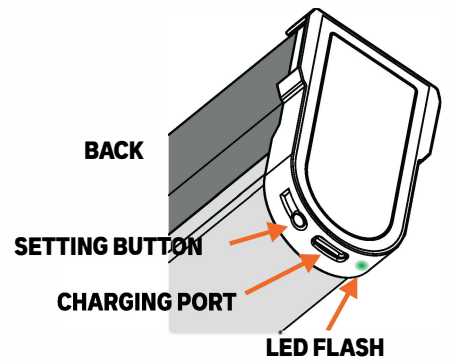

DELETE A CHANNEL FROM MOTOR

1. Select the desired shade **channel** (channel backlight will turn off after 4 secs).
2. Remove the battery cover to access the 'C' button.
3. While the motor beeps (max. 15 secs), press the 'C' button. The shade will **jog**, and the **green** LED will flash to confirm successful pairing.

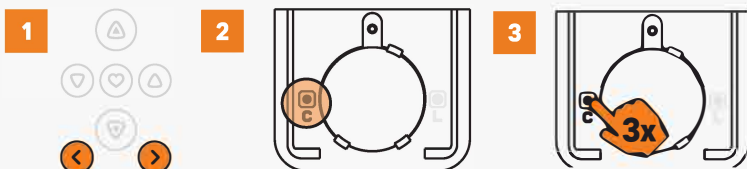

SETTING THE FAVOURITE POSITION

1. Send the shade to the desired favourite position.
2. Remove the battery cover to access the 'L' button.
3. Hold the 'L' button first, then quickly hold the **Heart** button until the shade beeps and the **green** LED blinks to set the favorite position.

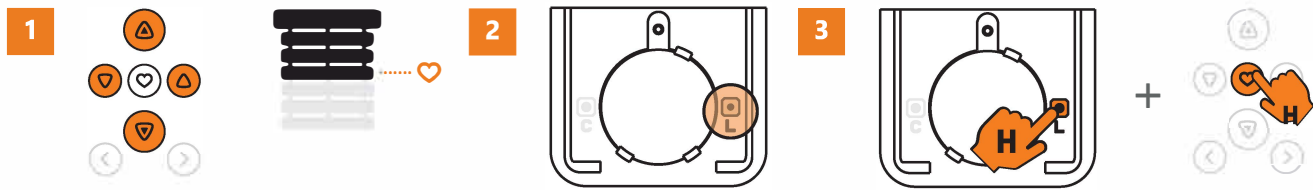

DETELE THE FAVOURITE POSITION

1. Press **Heart** to send the shade to its favourite position.
2. Remove the battery cover to access the 'L' button.
3. Hold the 'L' button first, then quickly hold the **Heart** button until the shade beeps and the **green** LED blinks to set the favorite position.

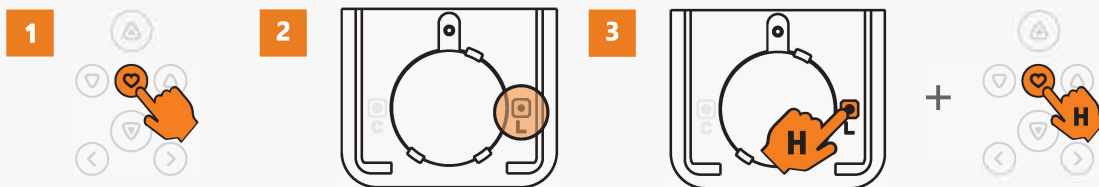

CHANGING THE MOTOR SPEED

A shade offers three speed levels: **Standard** (default), **Comfort**, and **Slow**. Changing the speed cycles to the next available level

1. Make sure the desired shade channel is active.
2. Hold **Heart** first, then quickly hold the **Up** button until the shade beeps and the **green** LED blinks to change the speed.

Note:

All shades on the same group channel will have their speed changed.

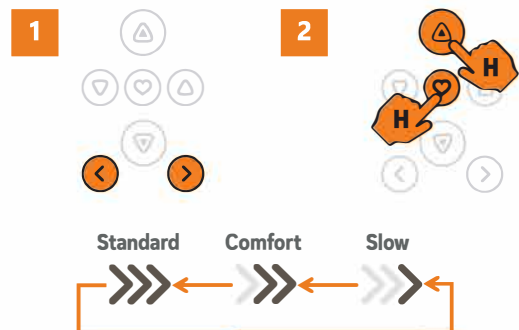

RECHARGING THE SHADE BATTERY

If the group channel number no longer lights up or the controlled product stops responding, it's time to replace the battery

1. Use the included Philips screwdriver to turn the captive screw counter clockwise until it loosens but remains attached to the cover.
2. Slide the battery cover off gently to access the battery compartment.
3. Carefully remove the old battery and align the battery with the + symbol facing upward. Place it into the socket, ensuring it is seated securely and held in place by the plastic snap legs.
4. Securely slide the battery cover back into position and tighten the captive screw.

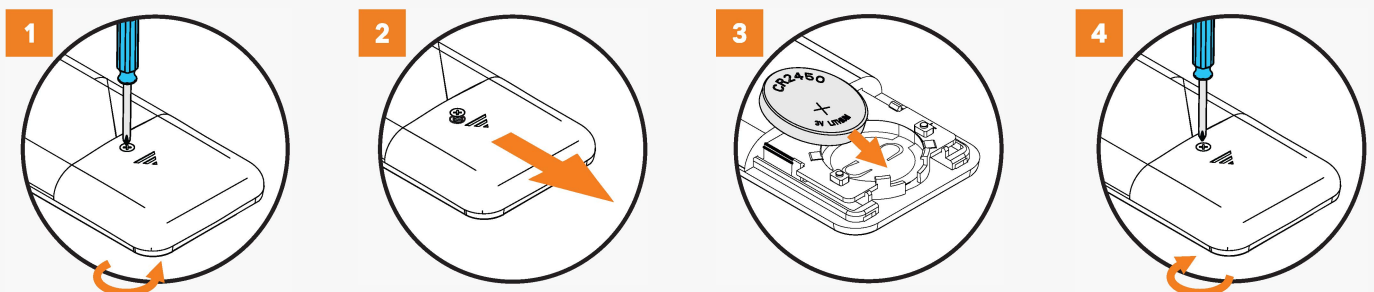

MOUNTING THE REMOTE HOLDER

NOTE: A wall mount remote holder is included with your remote, but it is optional to install it.

1. Determine where you'd like to place your remote carrier in the room. It is common to place it near a light switch, or on the wall next to the window.
2. With the holder in the upright position, insert the provided screws to secure it to our mounting surface.
3. After the screws are attached to the wall, insert the screws cap cover to the desired position in the remote holder.

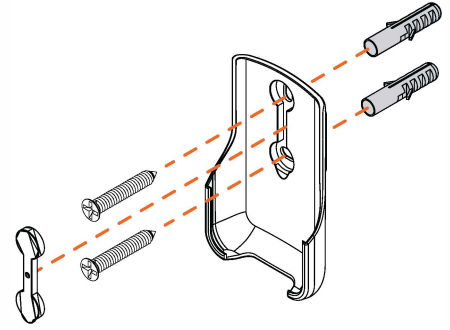

TROUBLESHOOTING

QUESTION	ANSWER
None of the backlit buttons illuminate on my remote when I press the buttons ?	Check if the battery needs replacement or is inserted properly and not damaged.
When I try to add a blind to the app or remote, there's no response ?	<ol style="list-style-type: none"> 1. Blind has no power. Make sure the motor is awake and not in deep sleep 2. Make sure the integrated Li-ion battery of the blind is charged. 3. Check if the correct group channel has been selected.

FREQUENTLY ASKED QUESTIONS

QUESTION	ANSWER
My shades are not responding to the remote control ?	<ol style="list-style-type: none"> 1. Check battery has been inserted correctly into remote control. 2. Check blinds have been added to the remote control. 3. Check battery level of the blind, via the app. 4. Go to: Settings > Blind Status, then press 'Connect'. 5. If battery level of the blind is good, replace remote control battery.
Can I add blinds to a remote control without using the app ?	<p>Yes. A remote control can be paired to a shade, if the app is not required. To do this:</p> <ol style="list-style-type: none"> 1. Choose the group number on the remote control that you want to add the blind to. 2. Remove the battery cover on the back of the remote control and locate the button marked 'C'. 3. Press and hold the manual push button on the blind until it jogs. Repeat the process until it jogs a 2nd time and persists making audible sound. 4. Press the 'C' button on the remote within 15 seconds until the blind jogs. Blind is now paired to the remote control.
Can I copy the same information from one remote control to another ?	No, it is not possible to copy stored information from one remote control to another.
Do I need a remote control to work my blinds?	For maximum flexibility and operation, one remote control per room, is recommended.
Can I assign more than one remote control to an individual blind?	<p>Yes, it is possible to assign up to a max. of 10 remotes to an individual shade. Repeat the following steps for each remote:</p> <ol style="list-style-type: none"> 1. Choose the group number on the remote control that you want to add the blind to. 2. Remove the battery cover on the back of the remote control and locate the button marked 'C'. 3. Press and hold the manual push button on the blind until it jogs. Repeat the process until it jogs a 2nd time and persists makes audible sound. 4. Press and hold the 'C' button on the remote control until the blind jogs. 5. The shade is now paired to the remote control.
How many blinds can the remote control operate?	<p>For model 5 channels remote:</p> <ul style="list-style-type: none"> • 1 remote control has 5 groups to choose from. • The maximum number of blinds that can be assigned to each group, is 16. <p>For model 14 channels remote:</p> <ul style="list-style-type: none"> • 1 remote control has 14 groups to choose from. • The maximum number of blinds that can be assigned to each group, is 16.
Which battery type is used for the remote control ?	The remote control will require a single 3V CR2450 coin / button cell battery.
Will the remote control work fresh out-of-the-box ?	No. The remote control will need to be assigned either directly to the shade or via the SmartView app.

SAFETY INSTRUCTIONS

WARNING: IMPORTANT SAFETY INSTRUCTIONS

Follow all instructions carefully, as incorrect installation or handling can lead to severe injury.

- Do not ingest the battery. This device contains a lithium coin/button cell battery. Swallowing the battery can cause severe internal burns within 2 hours and may lead to death.
- Keep new and used batteries away from children. If the battery compartment does not close securely (or lacks a captive screw), stop using the product immediately and keep it out of reach of children.
- If a battery is swallowed or placed inside any part of the body, seek immediate medical attention.
- Replacing the battery with an incorrect type may compromise safety features.
- Do not dispose of batteries in fire, hot ovens, or crush them, as this can lead to explosions or leakage of flammable liquids or gases.
- Avoid exposing batteries to extremely high temperatures or low air pressure, as this may cause explosions or leakage.
- Keep the device dry and do not paint it.
- Do not drop, knock, or shake the device, as rough handling can damage internal circuit boards.
- Ensure the shade can move freely without obstruction from objects.
- Do not allow children to play with the remote control



Do not drill in to the device!



Do not immerse into liquid



Never drop the device!



Avoid direct sunlight!

BATTERY RECYCLING INSTRUCTIONS

1. To responsibly dispose of the coin cell battery in your remote control:
2. **Do Not Discard in Regular Trash:** Coin cell batteries contain hazardous materials and must not be disposed of in household waste. Improper disposal can harm the environment.
3. **Locate a Recycling Center:**
In the **United States**, visit [Call2Recycle](#) to find a nearby battery recycling drop-off location. Many retail stores, including home improvement and electronics stores, accept used batteries for recycling.
In **Canada**, check with local recycling programs or visit [Call2Recycle Canada](#) to locate a drop-off site.
4. **Prepare the Battery for Recycling:** Before recycling, tape over the positive (+) terminal of the battery with clear or electrical tape to prevent accidental discharge or short-circuiting.
5. **Follow Local Guidelines:** Some municipalities may have additional guidelines for battery disposal. Always adhere to your local regulations to ensure safe handling and recycling.
6. By recycling your coin cell battery, you help protect the environment and comply with regulations in the US and Canada.



LEGAL INFORMATION

CE Statement

Hunter Douglas hereby declares that the RW5-G2 and RW14-G2 Remote Controls are in compliance with the basic requirements and other relevant provisions of the Electromagnetic Compatibility (EMC) Directive 2014/30/EU, Radio Equipment Directive (RED) 2014/53/EU and Low Voltage Directive (LVD) 2014/35/EU. The full text of the EC declaration of conformity can be obtained online: www.tuiss.com/certifications



UK Statement

Hunter Douglas hereby declares that the RW5-G2 and RW14-G2 Remote Controls are in compliance with the basic requirements and other relevant provisions of the Electromagnetic Compatibility Regulations 2016, Radio Equipment Regulations 2017 and Electrical Equipment (Safety) Regulations 2016. The full text of the UK declaration of conformity can be obtained online: www.tuiss.com/certifications



FCC Statement

FCC ID: 2BMQ2RW5RW14

This device complies with part 15 of the FCC Rules. Operation is subject to the following two conditions:

- (1) This device may not cause harmful interference, and
- (2) This device must accept any interference received, including interference that may cause undesired operation.

This equipment has been tested and found to comply with the limits for a Class B digital device, pursuant to part 15 of the FCC Rules. These limits are designed to provide reasonable protection against harmful interference in a residential installation.

This equipment generates, uses and can radiate radio frequency energy and, if not installed and used in accordance with the instructions, may cause harmful interference to radio communications. However, there is no guarantee that interference will not occur in a particular installation. If this equipment does cause harmful interference to radio or television reception, which can be determined by turning the equipment off and on, the user is encouraged to try to correct the interference by one or more of the following measures:

- Reorient or relocate the receiving antenna.
- Increase the separation between the equipment and receiver.
- Connect the equipment into an outlet on a circuit different from that to which the receiver is connected.
- Consult the dealer or an experienced radio/TV technician for help.

Innovation, Science and Economic Development Canada ICES-003 Compliance

IC: 33385-RW5RW14

CAN ICES-3 (B)/NMB-3(B)

This device contains license-exempt transmitter(s)/receiver(s) that comply with Innovation, Science and Economic Development Canada's license exempt RSS(s). Operation is subject to the following two conditions:

- (1) This device may not cause interference.
- (2) This device must accept any interference, including interference that may cause undesired operation of the device.

WARNING

STRANGULATION HAZARD — Young children can be strangled by cords. Immediately remove this product if a cord longer than 22 cm or a loop exceeding 44 cm around becomes accessible.

5. INSTALLING NO-DRILL BLINDS HEADRAIL

NOTE: The No-drill Blinds will already be installed onto the existing product headrail. Remove the product from the headrail before installing the shade.

PREPARING THE NO DRILL BLINDS HEADRAIL

1. Pull the lever from below or push down on the mechanism from above to retract the tension block.
2. To stick metal strips, peel the covers from the sticky pads on the back the stick one.
3. Stick padded adhesive tape on sides of the window opening where you'll be installing the No-Drill Blinds Headrail.

This is optional if you find that the No-Drill Blinds Headrail slips against the wall once the blind is fitted and this plate is only available on larger product.

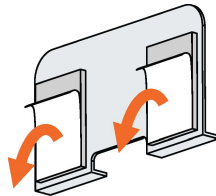

2. PEEL OFF COVERS

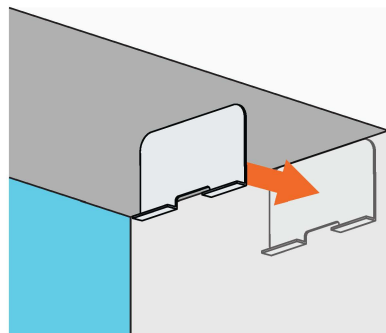

3. STICK TO THE SIDE WALL

INSTALLING THE NO DRILL BLINDS HEADRAIL

1. At the end of the headrail opposite to the lever there is an adjustment block that allows you to fine-tune the fittings of the rail.
2. Use a flat-head screwdriver to twist the small red plugs in toward the center of the headrail. Slide the block out of the headrail by a few millimeters, then twist the red plugs back into their original position to fix the block in place.
3. Make small adjustment only, repeating as necessary for a tight fit.
4. Hold the No-Drill Blinds Headrail up against the top of window opening and make it flush, then push the lever firmly upwards until the railsnaps into place.
5. Install the blind onto the brackets.

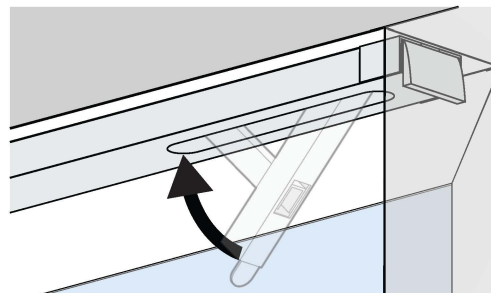
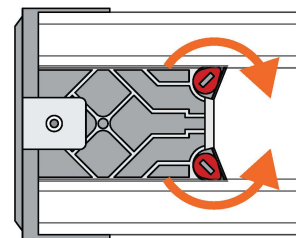

UNINSTALLING THE NO DRILL BLINDS HEADRAIL

Removing the product from the headrail by using a flat-head screwdriver to unlatch the lever. Make sure to hold the No-Drill Blinds Headrail in place while unlatching the lever. This will prevent damage to the window or headrail.

SETUP CODE

CODE DE CONFIGURATION

SBCAN

Getting to know your Smart Controller

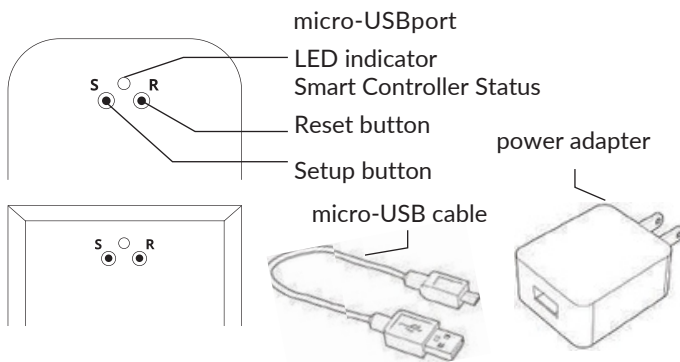

Smart Controller Status:
Flashing blue - Hotspot available
Flashing green - Connecting to the WiFi network
Pulsing cyan/blue-green - Connected to the Internet

Getting Started

1 Download the NeoSmart Blinds app



Download the app to your phone or tablet by searching **Neo Smart Blinds** on Google Play or the App Store.

Note: Do not install Neo Smart Blinds Blue

2 Plug in your Smart Controller in reach of your home WiFi

Choose a place not too far from your home router or a place you know has good WiFi signal strength. You will be able to change its location after, if necessary.

3 Create an account and choose the setup code written on the cover

After opening the app, tap on Create one to create a new account. Enter a valid email address and choose a password, select the region time zone from the place where the Smart Controller will be located. Choose the setup code written in the cover and tap on Register. **Follow**

4 the app step by step to add the Smart Controller

Have in hand the home WiFi password. It will be necessary to connect the Smart Controller to the Internet.

Note: Some Android users won't be connected quickly to the hotspot. If it is the case, please wait about 10 seconds before returning to the app. During this time, your device may notify you that the hotspot does not have Internet access, and will prompt you whether you want to remain connected. You need to select the option that will allow you to keep connected before returning to the app.

System requirements

- A strong WiFi signal (3barsormore) in the location where you will setup your Smart Controller.
- The Smart Controller only supports 2.4GHz WiFi (IEEE 802 11b/g/n), not 5GHz. WiFi security needs to be set to WPA-PSK or WPA2-PSK.
- A smartphone or tablet running Android 5.0 (Lollipop) or higher, or iOS 8 or higher is needed.

Troubleshooting

The home WiFi doesn't appear in the step 4

Try rescanning, if the problem persists, you will need to reposition the Smart Controller to a place with stronger WiFi signal. In this case, exit the process (tap on the menu, then tap Your Rooms), replace the Smart Controller and start over.

The Smart Controller LED in the bottom is not blinking blue

The process fails in the last step

Press the S button for 10 seconds, then press the R button once and start over. Pay special attention when typing the WiFi password.

Need more help?

about how to use the app and troubleshooting.

Integrations

Smart home devices

Visit neosmartblinds.com/smartcontroller-integrations for detailed information about connecting to Amazon Alexa, Google Home and other systems.

Control4

Please send an email to tech@neosmartblinds.com with your name, your email and your company's name. This information is necessary to always send to you any further driver update.

Legal Information

FCC

This equipment has been tested and found to comply with the limits for a Class B digital device, pursuant to Part 15 of the FCC Rules. These limits are designed to provide reasonable protection against harmful interference in a residential installation. This equipment generates uses and can radiate radio frequency energy and, if not installed and used in accordance with the instructions, may cause harmful interference to radio communications. However, there is no guarantee that interference will not occur in a particular installation. If this equipment does cause harmful interference to radio or television reception, which can be determined by turning the equipment off and on, the user is encouraged to try to correct the interference by one of the following measures:

- Reorient or relocate the receiving antenna.
- Increase the separation between the equipment and receiver.
- Connect the equipment into an outlet on a circuit different from that to which the receiver is connected.
- Consult the dealer or an experienced radio/TV technician for help

Contains transmitter module FCCID: COFWMNBM11

To comply with FCC/IC RF exposure limits for general population/ uncontrolled exposure, the antenna(s) used for this transmitter must be installed to provide a separation distance of at least 20 cm from all persons and must not be co-located or operating in conjunction with any other antenna or transmitter.

IC

This device complies with Industry Canada's licence-exempt RSSs. Operation is subject to the following two conditions:

- This device may not cause interference; and
- This device must accept any interference, including interference that may cause undesired operation of the device.

This device meets the exemption from the routine evaluation limits in section 2.5 of RSS102 and users can obtain Canadian information on RF exposure and compliance.

Contains transmitter module IC: 10293A-WMNB11

This End equipment should be installed and operated with a minimum distance of 20 centimeters between the radiator and your body.

